

## 产品规格书

产品类型 卡侬插头 (XLR Cable Connectors)

Product type

产品型号 SCSM3-B

Product NO.

客户名称

Customer

生产方	核准 (APPROVAL)	审核 (AUDIT)	制作 (COMPILE)
Manufacturer			

客户方	核准 (APPROVAL)	审核 (AUDIT)	承认 (ACCEPT)
(Customer)			

## 一、SCSM3-B 产品外观 (Product Appearance)



## 二、产品特性 (Product features)

- ✔ 全新的外观设计，操作更平滑  
New design for the Key, easy operate
- ✔ 新的接地（底盘和电缆接插件之间良好的完整接触）  
New ground contact-excellent contact integrity between chassis and cable connector
- ✔ 彩色尾套用于编码和识别  
Colored boots available for coding or identification
- ✔ 尾套带聚氨酯密封套，更大限度防止电缆受弯曲压影响  
Boot with polyurethane gland gives high protection to cable bending stresses

## 三、技术参数 (Technical parameters)

### 1. 产品参数 (Product parameters)

连接类型( Connection Type)	XLR
公母性( Gender)	male

### 2. 电气参数 (Electrical parameters)

触点间电容 (Capacitance between contacts)	$\leq 4\text{pF}$
接触电阻 (Contact resistance)	$\leq 3\text{m}\Omega$
介电强度 (Dielectric strength)	1.5kVdc
绝缘电阻 (Insulation resistance)	$> 10\text{G}\Omega$ (initial)

每触点间额定电流( Rated current per contact)	16A
额定电压( Rated voltage)	<50V

### 3.机械参数 (Mechanical parameters)

电缆线径 (Sign Cable O.D. )	Black Strain relief: 3.5-6mm White Strain relief : 6-8mm
插入力 (Insertion force)	≤ 20N
拔出力 (Withdrawal force)	≤ 20N
使用寿命 (Service life)	> 1000 mating cycles
电线尺寸 (Wire size)	Max. 2.5 mm <sup>2</sup>
电线尺寸 (Wire size)	Max. 14 AWG
锁定装置 (Locking device)	Latch lock

### 4.材料和环境 (Material and environmental parameters)

尾套 (Boot)	Polyurethan
触点 (Contacts)	Cu alloy
触点电镀 (Contact plating )	Ag
内芯 (Insert)	Polyamide (PA 66 +30 % GF)
外壳 (Shell)	Zinc diecast (ZnAl4Cu1)
外壳电镀 (Shell plating)	Black coating
线夹 (Strain relief)	Polyacetal (POM)
阻燃等级 (Flame-retardant grade)	UL 94 HB
防护等级 (Protection class)	IP40
使用温度范围 (Temperature range)	-30°C to +80°C

## 5.标准和规范 (Standard)

标准 (Standard)	IEC 61076-2-103
可焊性 (Solderability)	Complies with IEC 68-2-20

## 四、产品外形尺寸 (Product Profile)

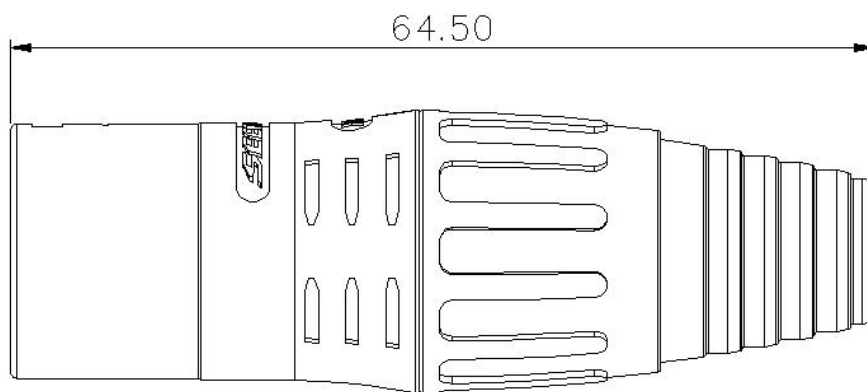
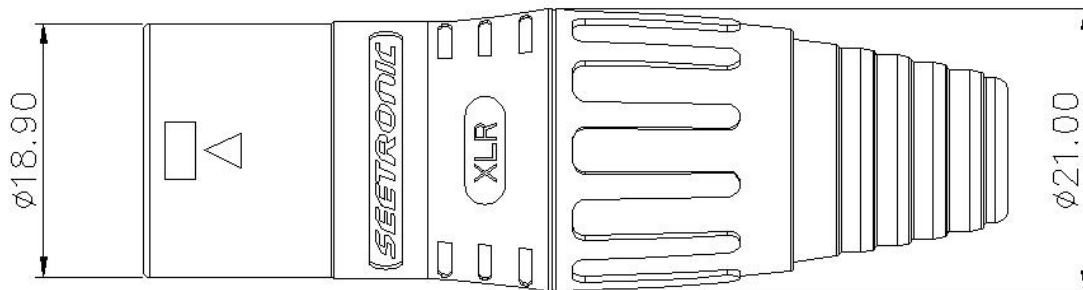

单位: mm

## 五、安装使用说明 (Installation instructions)

